



TECUMSEH HERMETIC CONDENSING UNIT

AVA4540EXTHL
TPC__rev 03
February 27, 2004

Model AVA4540EXTHL
BOM 2K3128-2E

Air Cooled 3 HP
Application High Temp
Refrigerant R 22

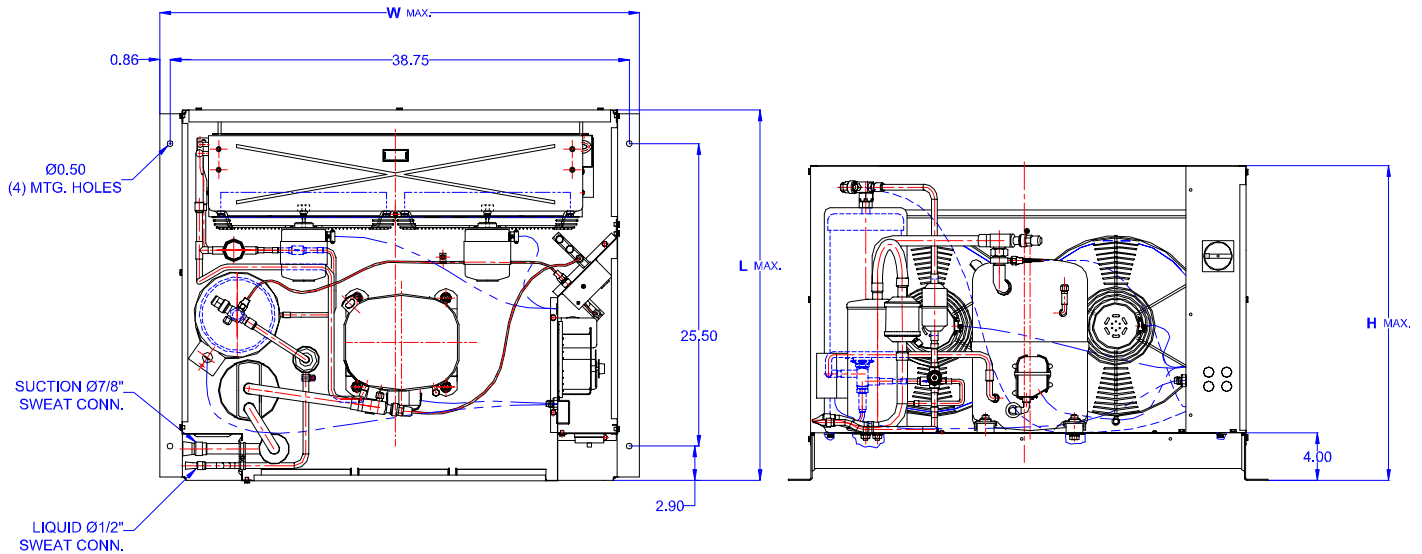
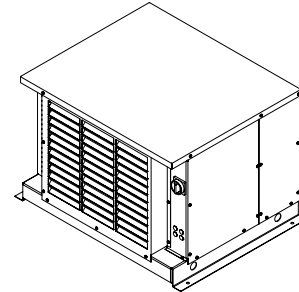

Model	Dimensions (inch)			Line connections		Pumpdown	Air flow	Oil Ch.	Gross weight
	L	W	H	Suction	Liquid	90% @ 90°F	SCFM	Oz.	Lbs.
AVA4540EXTHL	31.50	40.50	26.75	7/8 Sweat	1/2 Sweat	26.38	1550	55	320

Factory charge 20 psig dry air, **MUST BE EVACUATED**

Evaporator	Ambient Temperatures																
	80°F					90°F				100°F				110°F			
°F	Psig	BTUH	Watts	Head	Cond T	BTUH	Watts	Head	Cond T	BTUH	Watts	Head	Cond T	BTUH	Watts	Head	Cond T
10	32.8	21043	2978	198	100	19641	3064	226	108	17326	3095	257	119	15487	3131	290	128
15	37.7	24192	3159	207	103	22233	3257	235	111	19833	3314	266	122	17919	3365	300	130
20	43.0	27061	3352	216	105	24901	3461	244	114	22389	3542	276	124	20369	3611	310	132
25	48.7	30010	3557	226	108	27646	3677	254	117	24996	3780	287	127	22840	3869	322	135
30	54.8	33039	3775	237	112	30467	3904	265	121	27652	4028	298	130	25329	4138	334	138
35	61.4	36148	4005	249	117	33364	4143	277	123	30358	4286	310	132	27839	4419	346	141
40	68.5	39336	4247	261	119	36337	4393	289	127	33114	4553	323	136	30367	4712	360	144
45	76.0	42604	4501	275	123	39386	4655	302	131	35920	4830	336	138	32915	5017	374	147
50	84.0	45952	4768	289	127	42512	4928	316	134	38776	5116	350	142	35483	5333	389	151
55	92.6	49379	5047	303	131	45714	5213	331	137	41682	5412	364	145	38070	5660	404	154

