



TECUMSEH HERMETIC CONDENSING UNIT

AWG4524EXNHL
TPC__rev 03
February 27, 2004

Model **AWG4524EXNHL**
BOM **2K2103-2E**

Air Cooled **2 HP**
Application **High Temp**
Refrigerant **R 22**

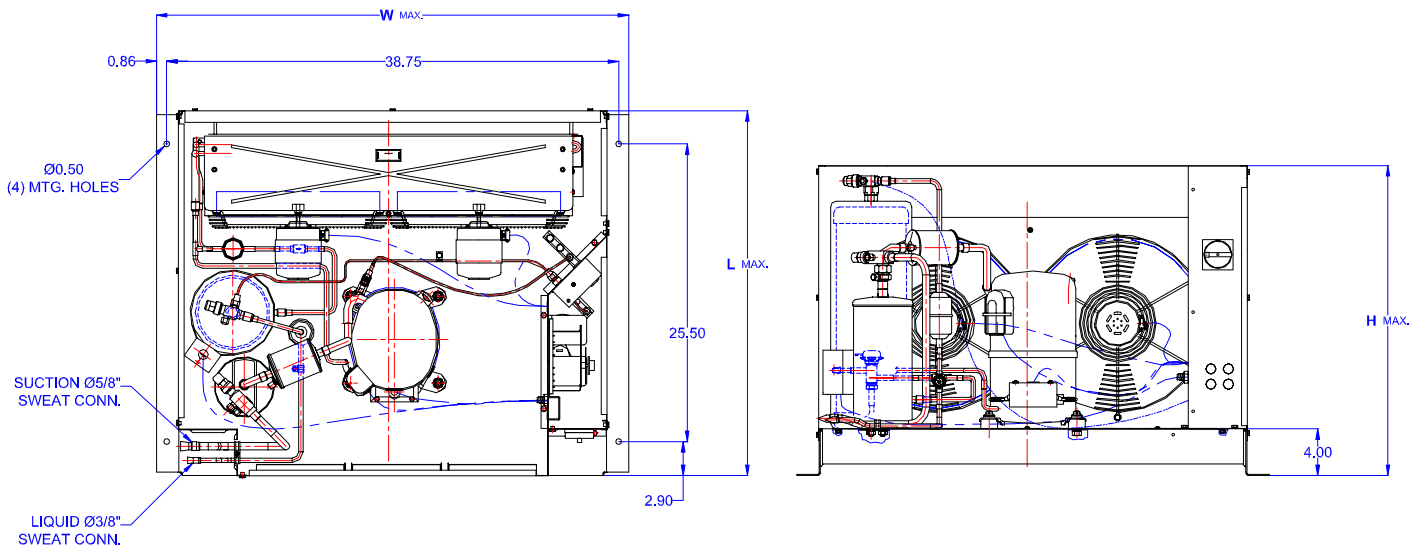
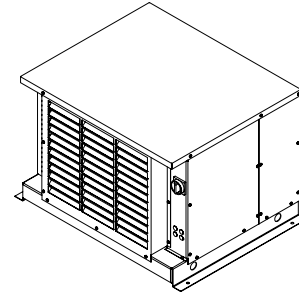

Model	Dimensions (inch)			Line connections		Pumpdown	Air flow	Oil Ch.	Gross weight
	L	W	H	Suction	Liquid	90% @ 90°F	SCFM	Oz.	Lbs.
AWG4524EXNHL	31.50	40.50	26.75	5/8 Sweat	3/8 Sweat	26.07	1850	38	300

Factory charge 20 psig dry air, **MUST BE EVACUATED**

Evaporator	Ambient Temperatures																
	80°F					90°F				100°F				110°F			
°F	Psig	BTUH	Watts	Head	Cond T	BTUH	Watts	Head	Cond T	BTUH	Watts	Head	Cond T	BTUH	Watts	Head	Cond T
10	32.8	12606	1824	189	97	11408	1863	215	105	10060	1881	245	114	8923	1903	278	125
15	37.7	14386	1942	195	99	12996	1896	222	108	11615	2028	253	117	10355	2059	286	126
20	43.0	16223	2058	202	102	14663	2109	229	110	13228	2172	261	119	11844	2212	294	129
25	48.7	18116	2171	209	103	16408	2232	237	112	14899	2313	269	121	13390	2361	302	131
30	54.8	20066	2282	217	106	18232	2354	245	114	16628	2452	278	125	14992	2507	311	133
35	61.4	22073	2390	225	108	20134	2477	254	117	18415	2587	287	127	16652	2650	321	135
40	68.5	24136	2496	234	111	22115	2599	263	121	20260	2719	296	129	18386	2789	331	137
45	76.0	26256	2600	243	115	24174	2721	273	122	22163	2848	306	132	20141	2924	341	140
50	84.0	28433	2701	252	117	26312	2843	283	126	24124	2974	316	134	21971	3056	352	142
55	92.6	30677	2800	263	121	28528	2964	294	129	26144	3098	327	136	23858	3185	364	145

Performance @ 60 Hz, Return Gas Temperature 65°F, --- SubCooling 5°F

