

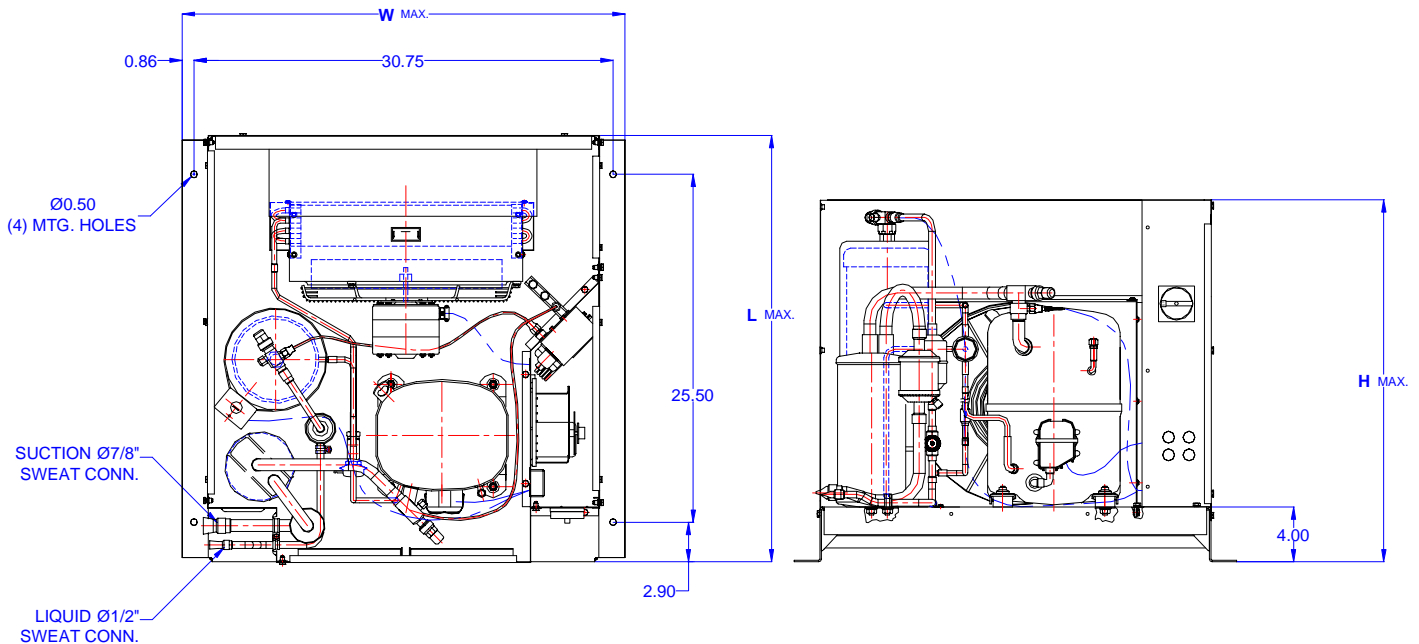

TECUMSEH HERMETIC CONDENSING UNIT

AVA2510ZXNHL
TPC__rev 02
February 27, 2004

Model AVA2510ZXNHL
BOM 2K2116-2E
Air Cooled 2 1/2 HP
Application Low Temp
Refrigerant R404A

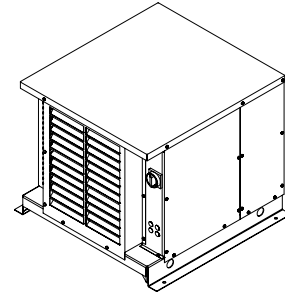

Model	Dimensions (inch)			Line connections		Pumpdown	Air flow	Oil Ch.	Gross weight
	L	W	H	Suction	Liquid	90% @ 90°F	SCFM	Oz.	Lbs.
AVA2510ZXNHL	31.50	32.50	26.75	7/8 Sweat	3/8 Sweat	21.75	800	54	250

Factory charge 20 psig dry air, **MUST BE EVACUATED**

Evaporator	Ambient Temperatures																
	85°F					90°F				100°F				110°F			
°F	Psig	BTUH	Watts	Head	Cond T	BTUH	Watts	Head	Cond T	BTUH	Watts	Head	Cond T	BTUH	Watts	Head	Cond T
-40	5.5	4093	1573	223	95	3592	1522	237	100	2884	1486	267	108	2329	1370	303	118
-35	8.0	5223	1744	231	98	4675	1703	246	102	3839	1655	276	111	3088	1558	312	120
-30	10.7	6348	1927	241	101	5751	1894	256	105	4785	1839	287	114	3856	1758	321	122
-25	14.0	7469	2121	252	104	6822	2097	267	108	5721	2037	298	116	4633	1971	332	125
-20	17.1	8586	2327	263	107	7887	2311	278	111	6647	2250	310	119	5417	2196	344	127
-15	19.3	9699	2545	275	110	8946	2536	291	115	7564	2477	323	122	6210	2434	357	130
-10	24.5	10807	2775	290	114	9999	2772	305	118	8471	2719	337	126	7011	2684	370	133
-5	28.8	11912	3017	304	117	11046	3019	319	121	9368	2976	352	129	7820	2947	385	136
0	33.5	13011	3270	319	121	12088	3277	335	125	10256	3248	368	132	8638	3222	401	139
5	36.5	14107	3535	335	125	13123	3546	351	129	11135	3534	385	136	9463	3510	418	143
10	43.7	15199	3812	352	129	14153	3826	369	132	12003	3835	403	140	10298	3810	436	146

Performance @ 60 Hz, Return Gas Temperature 40°F, --- SubCooling 5°F

