

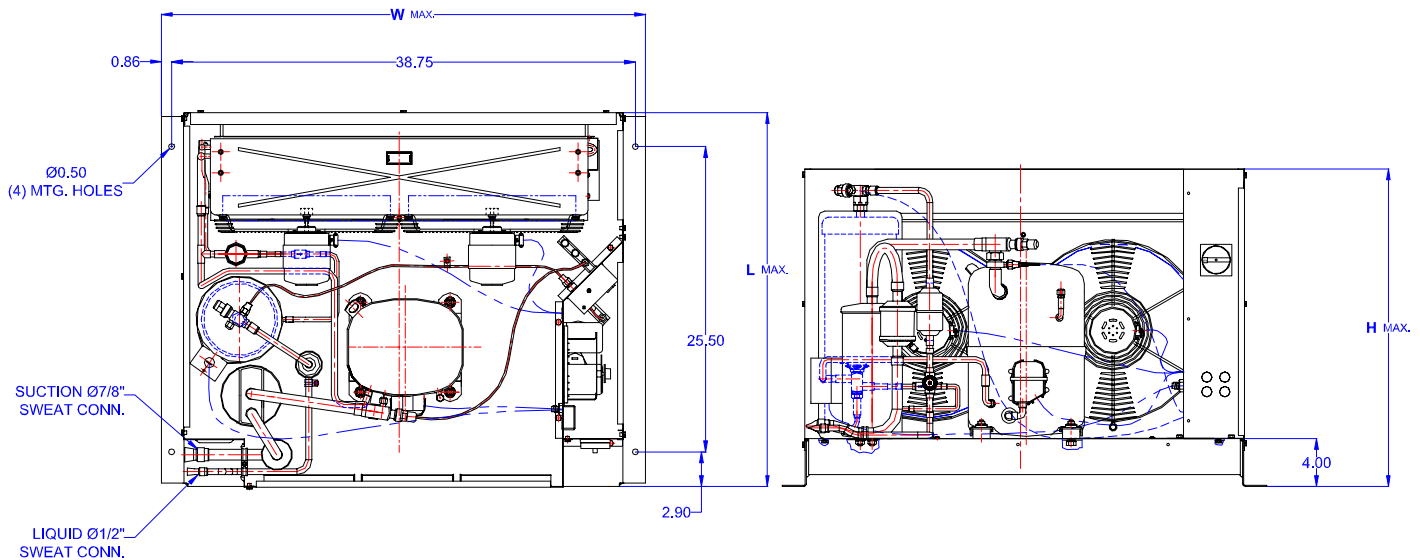

TECUMSEH HERMETIC CONDENSING UNIT

AVA2512ZXNHL
TPC rev 04
March 23, 2004

Model AVA2512ZXNHL
BOM 2K3140-2E
Air Cooled 2 3/4 HP
Application Low Temp
Refrigerant R404A

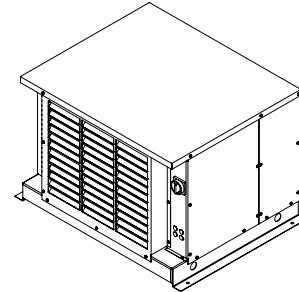

Model	Dimensions (inch)			Line connections		Pumpdown	Air flow	Oil Ch.	Gross weight
	L	W	H	Suction	Liquid	90% @ 90°F	SCFM	Oz.	Lbs.
AVA2512ZXNHL	31.50	40.50	26.75	7/8 Sweat	1/2 Sweat	22.63	1600	54	320

Factory charge 20 psig dry air, **MUST BE EVACUATED**

Evaporator	Ambient Temperatures																
	85°F				90°F				100°F				110°F				
°F	Psig	BTUH	Watts	Head	Cond T	BTUH	Watts	Head	Cond T	BTUH	Watts	Head	Cond T	BTUH	Watts	Head	Cond T
-40	5.5	4068	1695	215	98	4139	1661	231	98	3245	1501	268	108	2429	822	292	115
-35	8.0	5342	1854	222	95	5313	1828	238	100	4296	1677	273	110	3499	1151	300	117
-30	10.7	6662	2023	229	97	6531	2005	244	102	5387	1863	278	111	4582	1470	308	119
-25	14.0	8027	2202	237	100	7794	2192	252	104	6518	2057	285	113	5678	1779	317	121
-20	17.1	9437	2392	244	102	9102	2389	260	106	7689	2260	292	115	6786	2078	326	123
-15	19.3	10893	2591	254	104	10454	2596	269	109	8900	2471	300	117	7907	2367	335	125
-10	24.5	12393	2801	263	106	11851	2813	278	111	10151	2692	309	119	9041	2646	345	128
-5	28.8	13939	3021	273	109	13292	3040	288	114	11442	2921	319	121	10187	2915	355	130
0	33.5	15530	3251	284	112	14778	3277	299	116	12772	3159	329	124	11345	3174	366	132
5	36.5	17166	3490	295	114	16309	3524	311	119	14142	3405	340	126	12517	3423	378	134
10	43.7	18848	3741	307	117	17884	3781	323	122	15553	3661	353	129	13701	3662	389	137

Performance @ 60 Hz, Return Gas Temperature 40°F, --- SubCooling 5°F

