

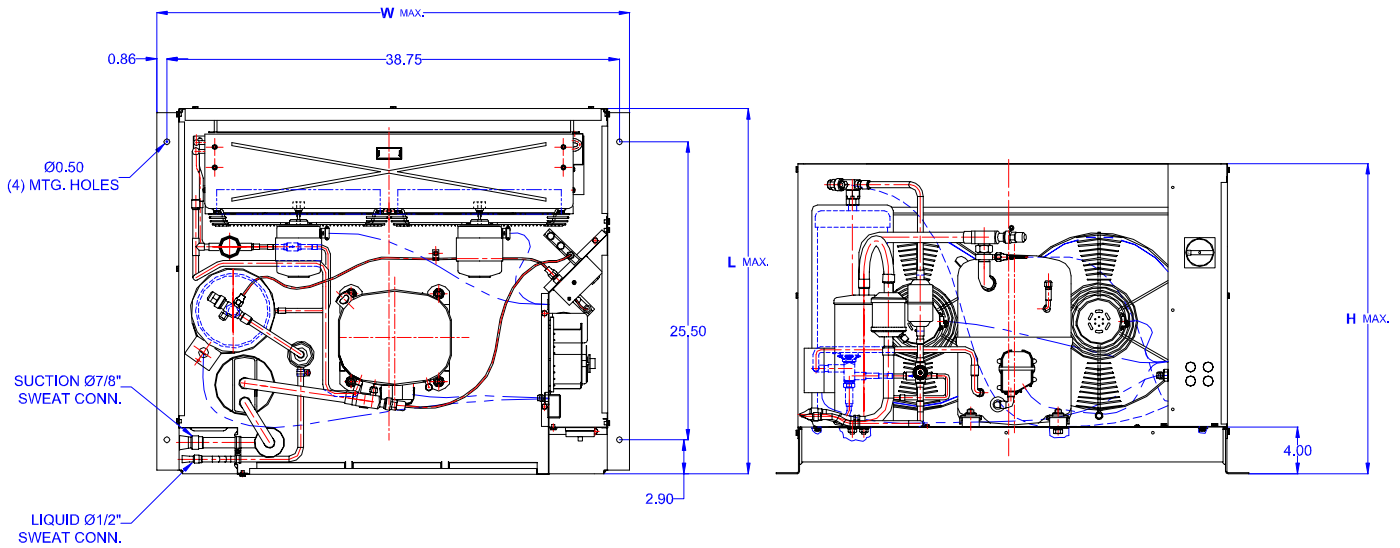

TECUMSEH HERMETIC CONDENSING UNIT

AVA2515ZXNHL
TPC__rev 03
February 27, 2004

Model AVA2515ZXNHL
BOM 2K3144-2E
Air Cooled 3 HP
Application Low Temp
Refrigerant R404A

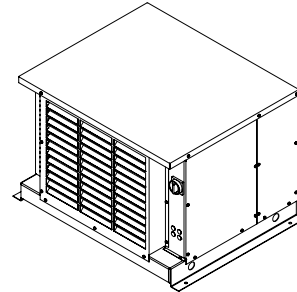

Model	Dimensions (inch)			Line connections		Pumpdown	Air flow	Oil Ch.	Gross weight
	L	W	H	Suction	Liquid	90% @ 90°F	SCFM	Oz.	Lbs.
AVA2515ZXNHL	31.50	40.50	26.75	7/8 Sweat	1/2 Sweat	22.90	1600	54	320

Factory charge 20 psig dry air, **MUST BE EVACUATED**

Evaporator	Ambient Temperatures																
	85°F					90°F				100°F				110°F			
°F	Psig	BTUH	Watts	Head	Cond T	BTUH	Watts	Head	Cond T	BTUH	Watts	Head	Cond T	BTUH	Watts	Head	Cond T
-40	5.5	5512	1883	215	93	5131	1869	231	98	3359	1662	262	107				
-35	8.0	6852	2099	219	94	6404	2083	234	99	4762	1928	266	108				
-30	10.7	8575	2365	224	96	7791	2311	239	100	6211	2202	271	110	3655	1722	304	118
-25	14.0	10158	2603	230	98	9291	2554	245	102	7705	2483	277	111	5144	2073	310	119
-20	17.1	11863	2853	236	100	10905	2811	252	104	9244	2772	283	113	6661	2424	317	121
-15	19.3	13691	3117	244	102	12633	3082	259	106	10830	3068	291	115	8206	2775	325	123
-10	24.5	15641	3392	253	104	14475	3367	268	108	12461	3372	301	117	9779	3126	334	125
-5	28.8	17692	3681	263	106	16431	3667	279	111	14138	3683	311	119	11831	3477	343	127
0	33.5	19909	3983	274	110	18500	3981	290	114	15861	4002	322	122	13011	3828	354	129
5	36.5	22227	4297	285	113	20683	4309	302	117	17629	4328	334	125	14669	4179	366	132
10	43.7	24668	4624	299	116	22980	4652	316	120	19443	4662	348	128	16356	4530	378	135

Performance @ 60 Hz, Return Gas Temperature 40°F, --- SubCooling 5°F

