

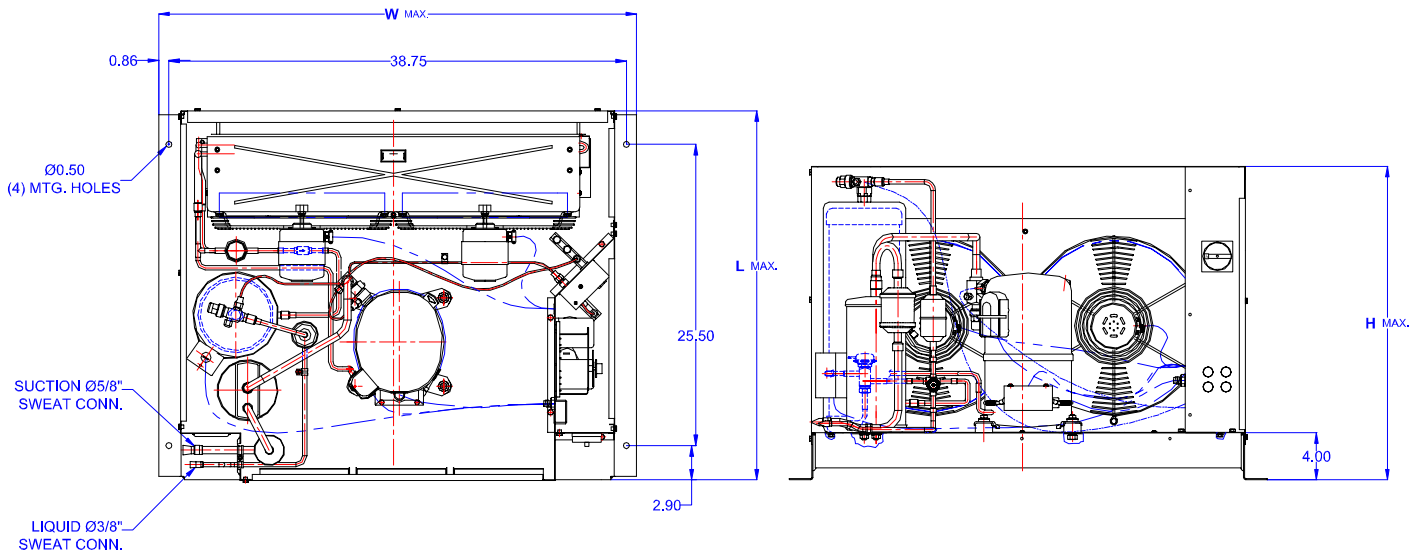

TECUMSEH HERMETIC CONDENSING UNIT

AWA2490ZXDHL
TPC__rev 02
February 27, 2004

Model **AWA2490ZXDHL**
BOM **2K2111-2E**
Air Cooled **2 1/4 HP**
Application **Low Temp**
Refrigerant **R404A**

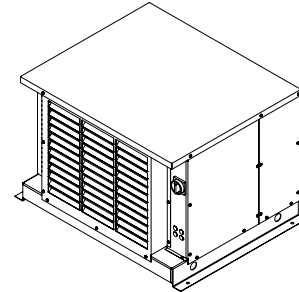

Model	Dimensions (inch)			Line connections		Pumpdown	Air flow	Oil Ch.	Gross weight
	L	W	H	Suction	Liquid	90% @ 90°F	SCFM	Oz.	Lbs.
AWA2490ZXDHL	31.50	40.50	26.75	5/8 Sweat	3/8 Sweat	22.61	1750	38	300

Factory charge 20 psig dry air, **MUST BE EVACUATED**

Evaporator	Ambient Temperatures																
	85°F					90°F				100°F				110°F			
°F	Psig	BTUH	Watts	Head	Cond T	BTUH	Watts	Head	Cond T	BTUH	Watts	Head	Cond T	BTUH	Watts	Head	Cond T
-30	10.7	4624	1515	218	93	4098	1492	226	97	3565	1468	263	107	3571	1558	300	117
-25	14.0	5757	1665	217	94	5212	1650	231	98	4420	1622	267	108	4348	1723	305	118
-20	17.1	6936	1815	221	93	6365	1807	235	94	5344	1778	271	109	5199	1891	311	1210
-15	19.3	8165	1964	226	97	7558	1963	241	100	6336	1936	275	110	6123	2061	317	121
-10	24.5	9442	2114	232	98	8790	2118	247	102	7396	2097	281	111	7120	2234	323	122
-5	28.8	10767	2264	238	100	10061	2271	253	105	8525	2261	287	114	8190	2409	330	124
0	33.5	12141	2413	244	102	11372	2423	259	106	9721	2427	293	115	9334	2587	337	125
5	36.5	13563	2562	251	103	12722	2573	266	108	10986	2595	301	117	10552	2767	345	127
10	43.7	14836	2713	258	105	14112	2722	274	110	12319	2767	309	119				

Performance @ 60 Hz, Return Gas Temperature 40°F, --- SubCooling 5°F

Parts/Specifications

STANDARD		OPTIONAL	
Unit BOM	2K2111-2E	Fan Motor	810S050A99
Unit MODEL	AWA2490ZXDHL	Fan Motor Qty	2
		Fan Motor RLA	1.3
Refrigeration RANGE	-40F TO +10F	Fan Blade	51568
Design Pressure Low	181	Fan Guard	70831
Design Pressure High	450	Shroud	70648-2
Volts - HZ - Ph	208-230-60-1		
Voltage Range	253 - 197	High Pressure switch	84095-2
Min. Circuit Ampacity	18.4	Low Pressure Control	84026-D
Max. Fuse Size	30	Dual Pressure Control	
		Condenser	50855
Compressor MODEL	AWA2460ZXD	Head Master Valve	LAC-4-215-3/8
Compressor BOM	AW613ET-111-A2	Check Valve	CV-020-1011
Compressor LRA	86	Process Valve	
Compressor RLA	12.6	Liquid Valve	31590
OverLoad	Internal	Suction Valve	31531-1
Relay	820ARR3J50		
Run Capacitor	85PR370F21	Receiver	51082-2
Run Capacitor Rating	45MFD 370V(M)VDE	Receiver Qty	1
Start Capacitor	85PS330D17	Accumulator	TK00042000
Start Capacitor Rating	145-175 MFD 330V	Liquid Filter	5200-083D
Contactor	91014	Sight Glass	SG-06D
		Suction Filter	WSF-5S
Unit Drawing	DGU1918-9KE		
Wiring no Fan controls	WD21-2XT2	CrankCase Heater	91022-1

BOM INDEX DESCRIPTION	
2xYYYY- 2ERA(F)TnDS	
E	Enclosure
R	Receiver Heater
A	Adjustable fan control
F	Fixed fan Control
T1	Defrost timer option
T2	Defrost timer & Defrost Heaters Contactor
D	Disconnect
S	Solenoid liquid Valve (supplied loose)

