

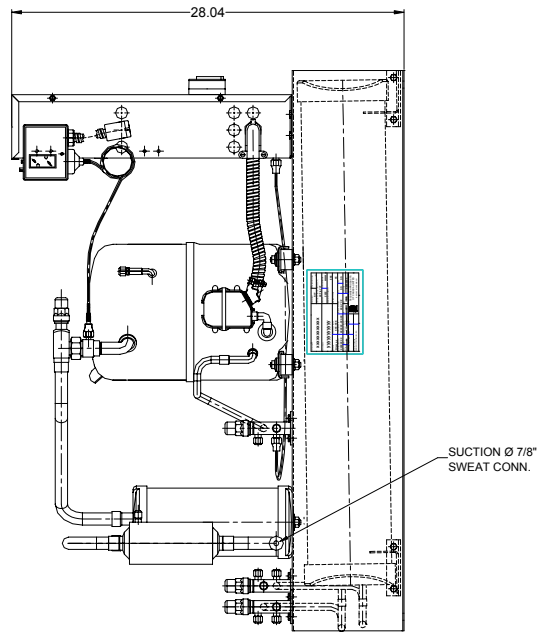

# TECUMSEH HERMETIC CONDENSING UNIT

AVA4542EXTRL  
TPC\_\_rev 01  
July 13, 2004

**Model** AVA4542EXTRL  
**BOM** 2R3128-2  
**Remote Condenser** 3 1/2 HP  
**Application** High Temp  
**Refrigerant** R 22

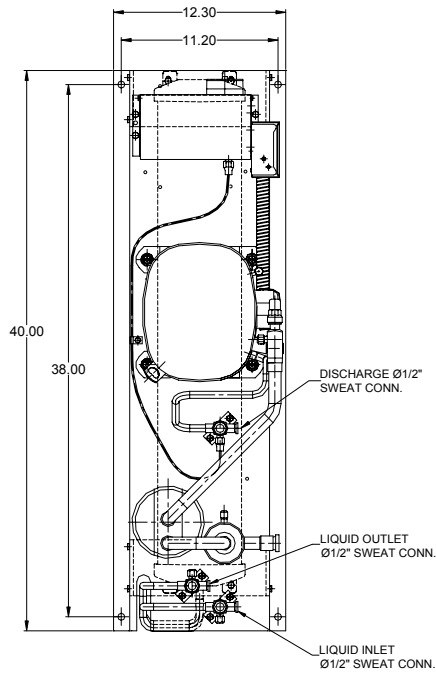
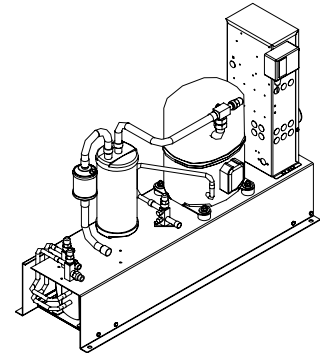

Model	Dimensions (inch)			Line connections		Pumpdown	Oil Ch.	Gross weight
	L	W	H	Suction	Liquid In/Out	90% @ 90°F	Oz.	Lbs.
<b>AVA4542EXTRL</b>	40.00	12.25	28.04	7/8 Sweat	1/2 Sweat	38.50	55	220

Factory charge 20 psig dry air, **MUST BE EVACUATED**

Evaporator	Condensing Temperatures													
	95°F		100°F		110°F		115°F		120°F		130°F		140°F	
°F	BTUH	Watts	BTUH	Watts	BTUH	Watts	BTUH	Watts	BTUH	Watts	BTUH	Watts	BTUH	Watts
5	19550	2357	18373	2393	16184	2457	15164	2483	14187	2502	12347	2518	<del>10634</del>	<del>2492</del>
10	22981	2500	21701	2551	19298	2647	18166	2688	17075	2723	14999	2770	13039	2777
20	30674	2745	29166	2829	26289	2988	24913	3061	23571	3129	20980	3241	18482	3313
30	39675	2928	37909	3044	34500	3269	32850	3376	31229	3476	28063	3655	24969	3794
40	50225	3036	48171	3186	44172	3478	42217	3618	40288	3752	36488	3998	32739	4206
<b>45</b>	<b>56155</b>	<b>3058</b>	<b>53947</b>	<b>3224</b>	<b>49630</b>	<b>3550</b>	<b>47513</b>	<b>3708</b>	<b>45418</b>	<b>3859</b>	<b>41279</b>	<b>4140</b>	<b>37180</b>	<b>4382</b>
50	62562	3056	60192	3239	55542	3600	53255	3775	50988	3944	46495	4259	42032	4537
55	69476	3029	66937	3230	61940	3625	59476	3817	57028	4004	52167	4355	47325	4668

Performance @ 60 Hz, SuperHeat 20°F, --- SubCooling 15°F

Parts/Specifications

STANDARD		OPTIONAL	
Unit BOM	2R3128-2	Fan Motor	
Unit MODEL	AVA4542EXTRL	Fan Motor RLA	
		Fan Blade	
Refrigeration RANGE	+20F TO +55F		
Design Pressure Low	150	High Pressure switch	84095-1
Design Pressure High	450	Low Pressure Control	84026-D
Volts - HZ - Ph	200-230-60-3	Dual Pressure Control	
Voltage Range	253 - 180		
Min. Circuit Ampacity	16.8	Receiver	51083
Max. Fuse Size	30	Accumulator	TK00042000
		Receiver In Valve	56566
Compressor MODEL	AVA5542EXT	Receiver Out Valve	56566
Compressor BOM	AV145RT-012-A2	Discharge Valve	56566
Compressor LRA	74	Suction Valve	31529-1
Compressor RLA	13.3		
		Suction Filter (7/8)	70822-5S
OverLoad	Internal		
Relay		CrankCase Heater	90699
Run Capacitor			
Run Capacitor Rating			
Start Capacitor			
Start Capacitor Rating			
Contactor	91014		
Unit Drawing	DGU1920-3R		
Wiring no Fan controls	WD23-RT2		

BOM INDEX DESCRIPTION

2Rxxxx-2TnDS

- T1 Defrost timer option
- T2 Defrost timer & Defrost Heaters Contactor
- D Disconnect
- S Solenoid liquid Valve (supplied loose)

**WARNING:** Installer must validate that tubing is sized in such a manner to insure adequate oil return. Oil level may require adjustment for long pipe runs.

