

TECUMSEH HERMETIC CONDENSING UNIT

AWA2488ZXTXU
TPC__rev 02
October 21, 2003

Model **AWA2488ZXTXU**
BOM **2W2002-1**

Water Cooled **2 HP**
Application **Low Temp**
Refrigerant **R 404A**

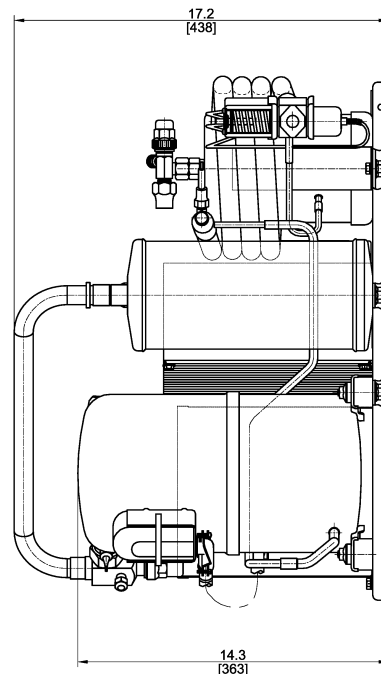
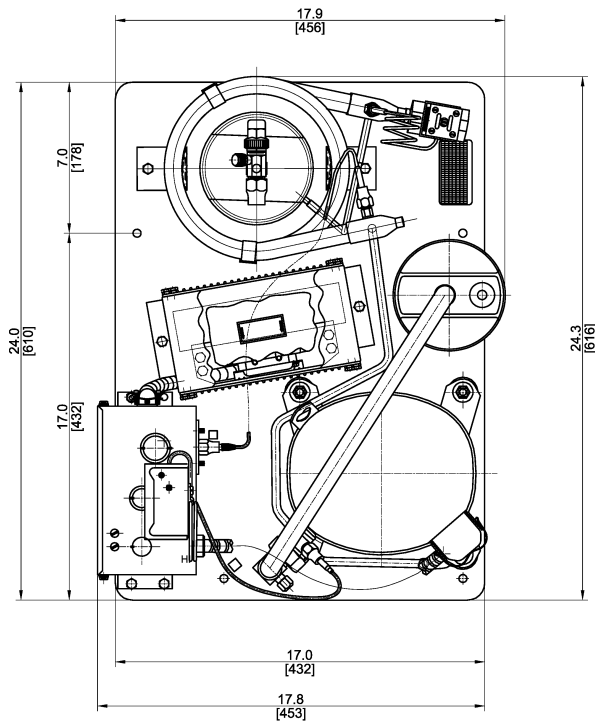
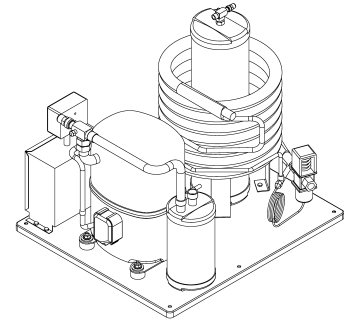

Model	Dimensions, inches				Line connection*		Pumdown	Oil Ch	Gr. Wt
	L	W	H	CH	Suction	Liquid	90° 90%	Oz.	Lbs.
AWA2488ZXTXU	24.3	17.9	17.2	14.3	7/8"S	3/8"F	5.1	38.0	119.0

*) Use 3/8" min. pipe size. Water inlet 3/8" NPT

Performance: Ambient 90 °F -- Return Gas 40 °F -- Condenser water in 75 °F -- Head 254 PSIG

Evaporator temperature °F	-40	-30	-20	-10	0	10
Capacity BTU/HR	2046	3796	6024	8764	12047	15908
Water Usage gpm	0.60	1.00	1.50	2.20	3.10	4.00
Watts	890	1191	1537	1891	2218	2483

The water valve should be adjusted to maintain a maximum of 95°F water outlet temperature in order to minimize water scaling within the condenser.

